

Assembly and Care Instructions

IMPORTANT!! CHECK TO MAKE SURE YOU HAVE ALL THE PARTS!! PLEASE READ ENTIRE INSTRUCTION SHEET BEFORE ASSEMBLY!!

STEP 1

Tighten each swivel caster (A, B) with wrench (D) onto bottom of base (C), as shown in **Figure 1**. Make sure you **TIGHTEN** them.

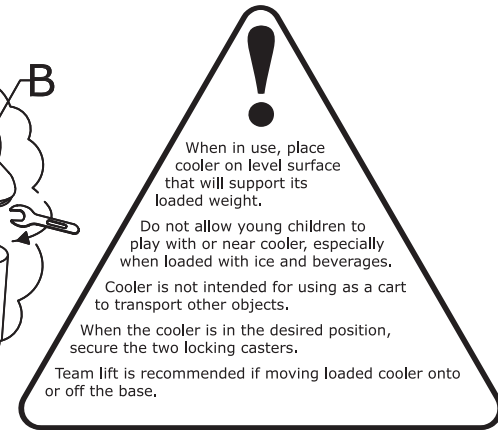
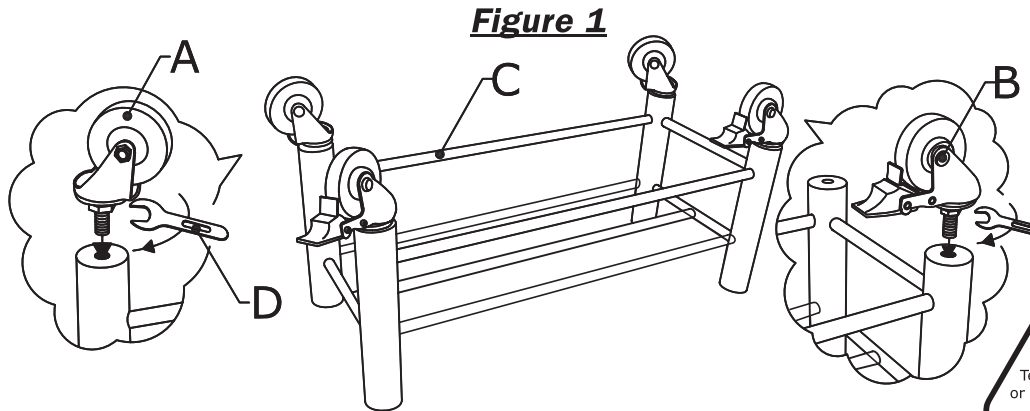

STEP 2

First install protective cap (E) onto extension (F). Then insert extension (F) into each base tube. See **Figure 2**.

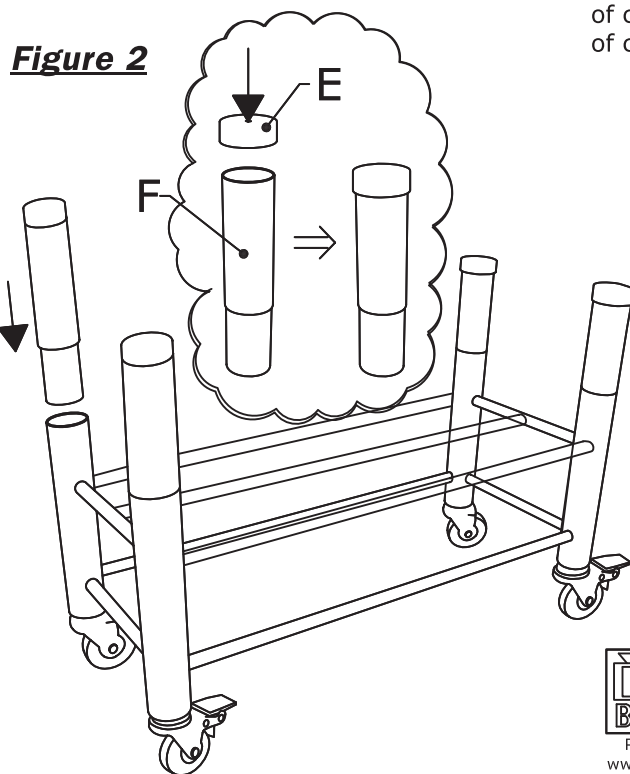

STEP 3

Set the cooler (G) on the assembled base with covers facing up. Make sure the base aligns correctly into the recessed bottom of cooler. Install cap catcher (H) into slots of cooler body. See **Figure 3**.

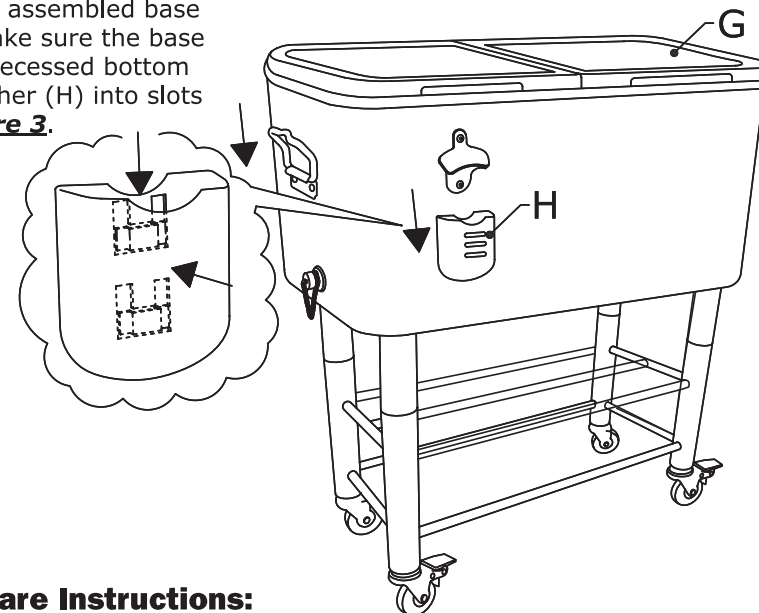

Safety and Care Instructions:

- ◆ To preserve the finish, clean with mild soap and water. Never use abrasive cleaners or scrub pads.

Missing a part?

There is no need to return this item to the store, instead call **TOLL FREE HOT LINE 1-800-PARTS-90**. Usually we can send out a FREE replacement within 72 hours. There is no charge for the missing parts. Office hours: 8:00 am to 5:00 pm EST.

A	Swivel caster	QTY	2
B	Locking swivel caster	QTY	2
C	Base	QTY	1
D	Wrench	QTY	1
E	Protective cap	QTY	4
F	Extension	QTY	4
G	Cooler body	QTY	1
H	Cap catcher	QTY	1



RIO Brands®
10981 Decatur Road
Philadelphia, PA 19154
www.riobrand.com

Made in China